

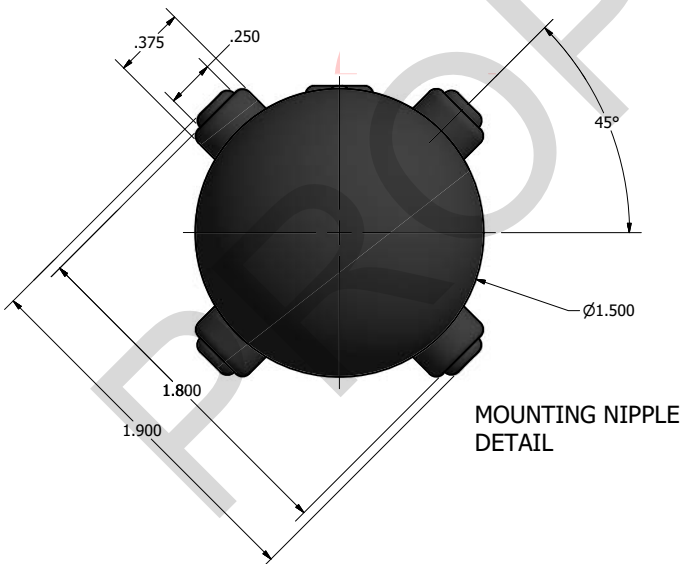

HTI-90-U / MAW-2-HC / AC  
MECHANICAL OUTLINE

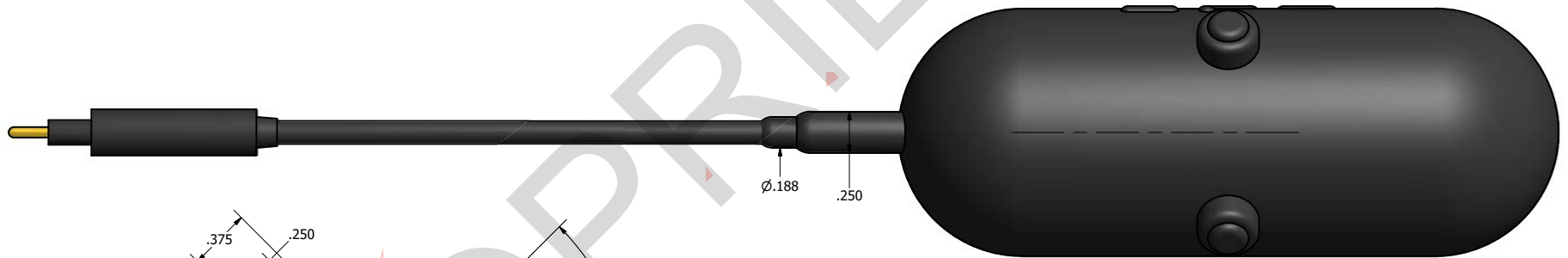
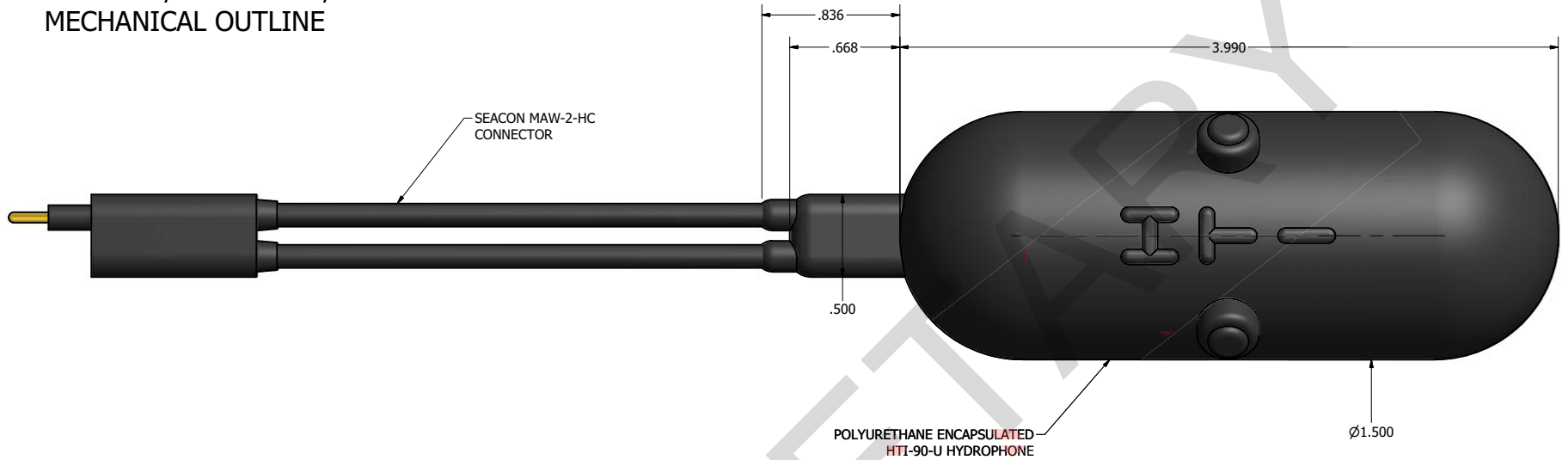

RELEASE TO AND ACCEPTED BY THE POSSESSOR ON CONDITION THAT NO RIGHTS OF REPRODUCTION OR USE ARE GIVEN EXCEPT FOR PURPOSE ELSEWHERE SPECIFIED IN WRITING BY HIGH TECH.				
DRAWN Scott	3/10/2016	 <b>HIGH TECH, INC.</b> 21120 JOHNSON RD. LONG BEACH, MS 39560 (228) 868-6632		
CHECKED				
QA				
MFG				
APPROVED				
TITLE HTI-90-U/MAW2/AC MECH OUTLINE		SIZE C	DWG NO 90-002-25-00-00	REV
SCALE		SHEET 1 OF 1		